

NEW

FLIR VUE™ PRO R

Radiometric Thermal Camera for sUAS



AERIAL RADIOMETRIC THERMAL IMAGING WITH VUE PRO R

The new Vue Pro R from FLIR gives drone operators and certified thermographers the power to gather accurate, non-contact temperature measurements from an aerial perspective. Every still image the Vue Pro R saves contains accurate, calibrated temperature data embedded in every pixel, adding even more value to your sUAS operations and services than ever. Still delivering the same industry-leading thermal imaging quality, interfaces, and capability as the best-selling Vue Pro, the Vue Pro R adds fully radiometric data-gathering to sUAS applications as diverse as building and roof inspections, power grid inspections, infrastructure analysis, precision agriculture, and public safety.



RADIOMETRIC THERMAL IMAGING FOR SUAS

- Accurate real-time, non-contact temperature measurement of vital structures and equipment
- Saves Radiometric JPEGs (RJPEGs) with temperature data embedded in every pixels
- Compatible with FLIR Tools for full post-flight analysis and report generation

RECORD THERMAL IMAGES TO AN ON-BOARD MICRO-SD CARD

- Record real-time thermal videos in MOV format
- Save 8-bit or 14-bit still images as JPEG, RJPEG, or TIFF formats
- MAVLink integration with convenient over RS-232 connection

FLEXIBLE CAMERA CONTROL AND CONFIGURATION OPTIONS

- Adjust camera functions with PWM inputs from your controller
- Configure your camera's recording and control settings with the Vue Pro mobile app
- Field-upgradeability makes sure you'll always have the latest features
- Simple power-in/analog video-out interface over 10-pin mini-USB connector
- Image settings optimized for airborne operations

3D TARGET

Via A. De Rege Thesauro 12
25135 - Brescia
tel. +39 02 00614452
www.3dtarget.it
info@3dtarget.it

www.flirvueproR.3dtarget.it



The World's **Sixth Sense**®

Specifications

Overview	
Thermal Imager	Uncooled VOx Microbolometer
Sensor Resolution	640x512
Lens Options (FOV for Full-Sensor Digital Output)	336 x 256
Lens Options* (FOV for NTSC Analog Output)	9 mm; 69° x 56° 13 mm; 45° x 37° 19 mm; 32° x 26°
Lens Options* (FOV for NTSC Analog Output)	6.8 mm; 45° x 35° 9 mm; 35° x 27° 13 mm; 25° x 19°
Spectral Band	7.5- 13.5 μm
Full Frame Rates	30 Hz (NTSC); 25 Hz (PAL)
Exportable Frame Rates	7.5 Hz (NTSC); 8.3 Hz (PAL)
Measurement Accuracy	+/-5°C or 5% of reading
Physical Attributes	
Size	2.26" x 1.75" (including lens)
Weight	3.25 - 4 oz (Configuration Dependent)
Precision Mounting Holes	Two M2x0.4 on each of two sides & bottom One 1/4-20 threaded hole on top
Image Processing & Display Controls	
Image Optimization for sUAS	Yes
Digital Detail Enhancement	Yes - Adjustable in GUI
Invertable Image?	Yes - Selectable in GUI
Polarity Control (black hot/white hot) & Color Palettes	Yes - Selectable in GUI
Interfacing	
Input Supply Voltage	4.0-6.0 VDC
Power Dissipation, steady state (max. 2.5W during shutter event of approximately 0.5 seconds)	<1.2W
	~1.0W
Environmental	
Operating Temperature Range	-20°C to +50°C
Non-Operating Temperature Range	-55°C to +95°C
Operational Altitude	+40,000 feet
Power/Video Module	
Input Power Range	5VDC - 28VDC
Reverse Polarity Protection?	Yes
Analog Video Output?	Yes
HDMI Output	1920x1080 @ 50hz, 60hz 1920x1080 @ 50hz, 60hz 1280x720 @ 50hz, 60hz 720x576 @ 50hz 720x480 @ 60hz

* Because the analog video output resolutions (640 x 480 and 320 x 240, respectively) are less than the full sensor resolution captured when saving digital stills and video, their resultant fields of view are slightly smaller as well. Both sets of values are shown here to allow operators the option of choosing the FOVs that most accurately reflect their pre-flight planning requirements.

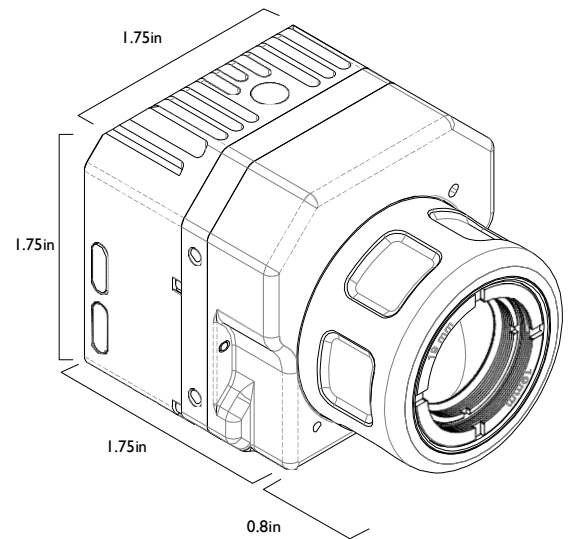

Vue Pro R with Power/Video Module attached

Power/Video Module

The Power/Video Module makes the Vue Pro and Vue Pro R easier to integrate than ever. Its 10-pin mini-USB connector accepts a wider input power range and provides reverse polarity protection while still providing analog video output and access to the camera's on-board storage. The micro-HDMI connector outputs HDMI video for live digital video downlink systems like DJI Lightbridge and 3DR Solo. All this in a package that's only 11 mm thick and weighs 15 grams.

Equipment described herein may require US Government authorization for export purposes. Diversion contrary to US law is prohibited. Imagery for illustration purposes only. Specifications are subject to change without notice. ©2016 FLIR Systems, Inc. All rights reserved. (Created 04/22)

3D TARGET

Via A. De Rege Thesauro 12
25135 - Brescia
tel. +39 02 00614452
www.3dtarget.it
info@3dtarget.it

www.flirvueproR.3dtarget.it

FLIR

The World's Sixth Sense®